



National Kaohsiung
CENTER FOR THE ARTS

WEI WU YINGGE

衛武營 國家藝術文化中心

國家表演藝術中心 National Performing Arts Center

表演廳

RECITAL HALL

技術製作資訊

Production Technical Information

Table of Contents

0 General Information	1
0-1 National Kaohsiung Center for the Arts (WEIWUYING)	1
0-2 Recital Hall	1
0-3 Traffic Information	2
0-4 Contact Information	2
0-5 Stage door	2
0-6 Auditorium / Seating	3
0-7 Plan	4
0-8 Section	5
1 Stage	6
1-1 Stage	6
1-2 Hoisting	7
2 Lighting	8
2-1 Lighting instrument	8
2-2 Accessories	8
2-3 Lighting Plan	9
2-4 Lighting Circuit	11
2-5 Portable Lift	13
2-6 Additional Power Supply	13
2-7 House Light / Working Light / Blackout	13
3 Audio/VideoSystems	14
3-1 Audio Facilities	14
3-2 Control Room	14
3-3 Stage Manager' s Desk	14
3-4 Microphone	14
3-5 Communications	15
3-6 Locations of Communications	15
3-7 Stage Cameras and Video Surveillance Systems	15
3-8 Paging Systems	15
4 Backstage Facilities	16
4-1 Dressing Rooms and Green Rooms	16
4-2 Orchestra Facilities	16
4-3 Pianos (shared between four <i>venues</i>)	16
4-4 Loading Dock	17
4-5 Other Facilities	19

Last updated:2018/09/26

0 General Information

0-1 National Kaohsiung Center for the Arts (WEIWUYING)

CENTER FOR THE ARTS, ARTS FOR THE PEOPLE , National Kaohsiung Center for the Arts will become one of the important theatre complexes of the international art field. It include four performance blocks, the 2,260-seat Opera House, the 2,000-seat Concert Hall, the 1,254-seat Play House and the 470-seat Recital Hall.



0-2 Recital Hall

The Recital Hall is mainly for chamber music, solo recitals, or other smaller performances. The sound-absorption can be adjusted to meet the needs with diverse types of performances, providing the most optimal acoustic effect.

The design is a variation of the traditional shoebox style, where a short partition wall is erected along the center line of the seating area to convert the Recital Hall into a vibrantly asymmetrical shoebox, while also providing reflection of direct sounds for the front seating area. To meet the needs of various types of performances, the sound-absorption value can be adjusted accordingly in the Recital Hall. An entire circle of sound-absorbing drapery behind the perforated wooden panels surrounds the upper half of the Recital Hall. The size of the drapery used is determined by performance genres so as to offer a superb acoustic effect.



0-3 Traffic Information

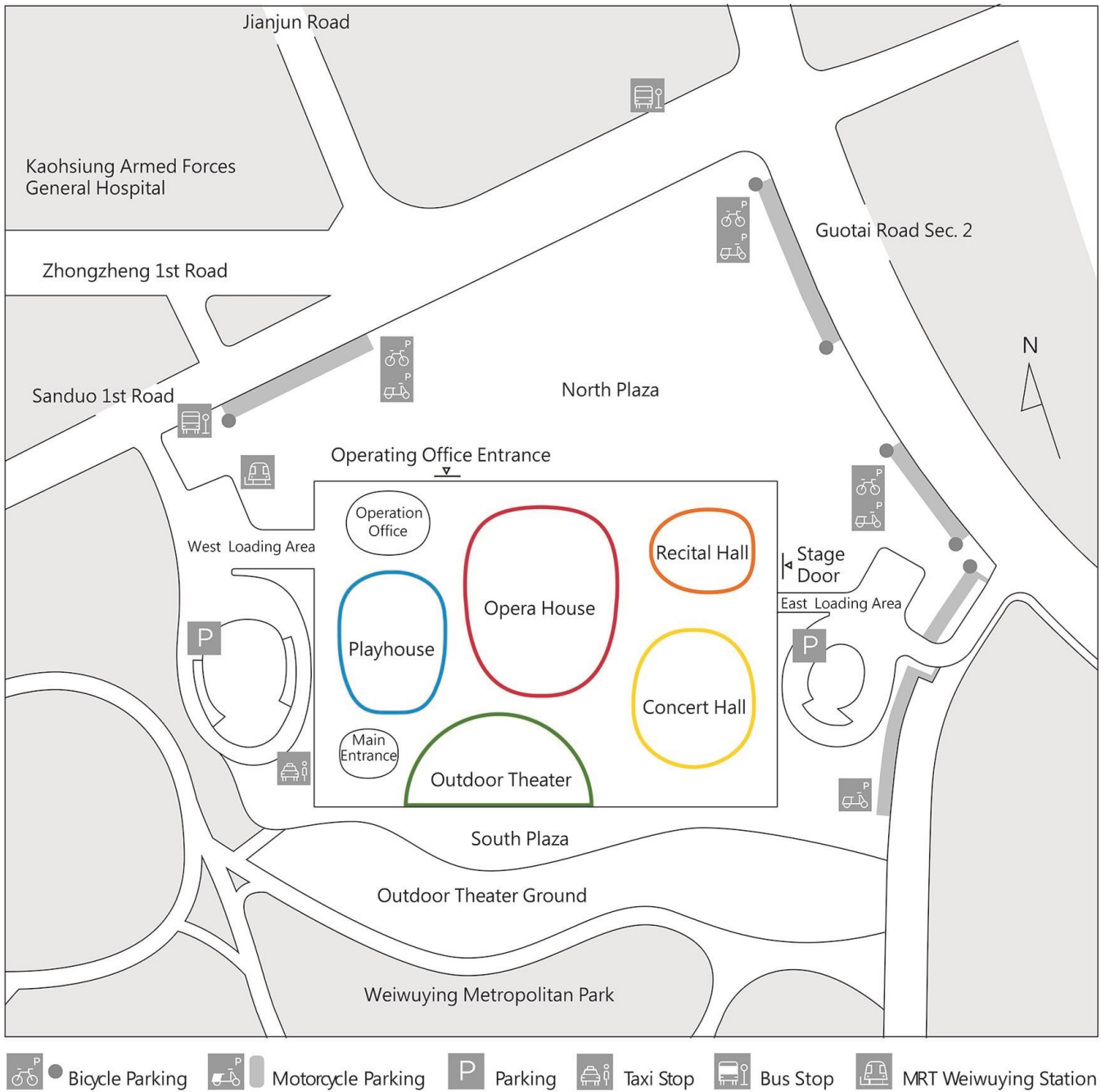

0-4 Contact Information

National Kaohsiung Center for the Arts (Weiwuying)

No.1, Sanduo 1st Rd., Fengshan Dist., Kaohsiung City 83075, Taiwan

+886 7-262-6666

service@npac-weiwuying.org

0-5 Stage door

Ground floor access is from the north and east side of building. Enter from Operating office entrance on Sanduo 1st Road or Stage Door on Guotai Road.

Basement Level 1 access is from Sanduo 1st Road entrance for Opera House and Playhouse ,Guotai Road entrance for Concert Hall and Recital Hall.

Working pass will be required for entry.

0-6 Auditorium / Seating

Capacities

Area	Capacities
Stalls (1F)	215 seats (include 2 working seats)
Wheelchairs	6 seats
Circle (2F)	198 seats
Box	15 seats
Total Capacity	434 seats

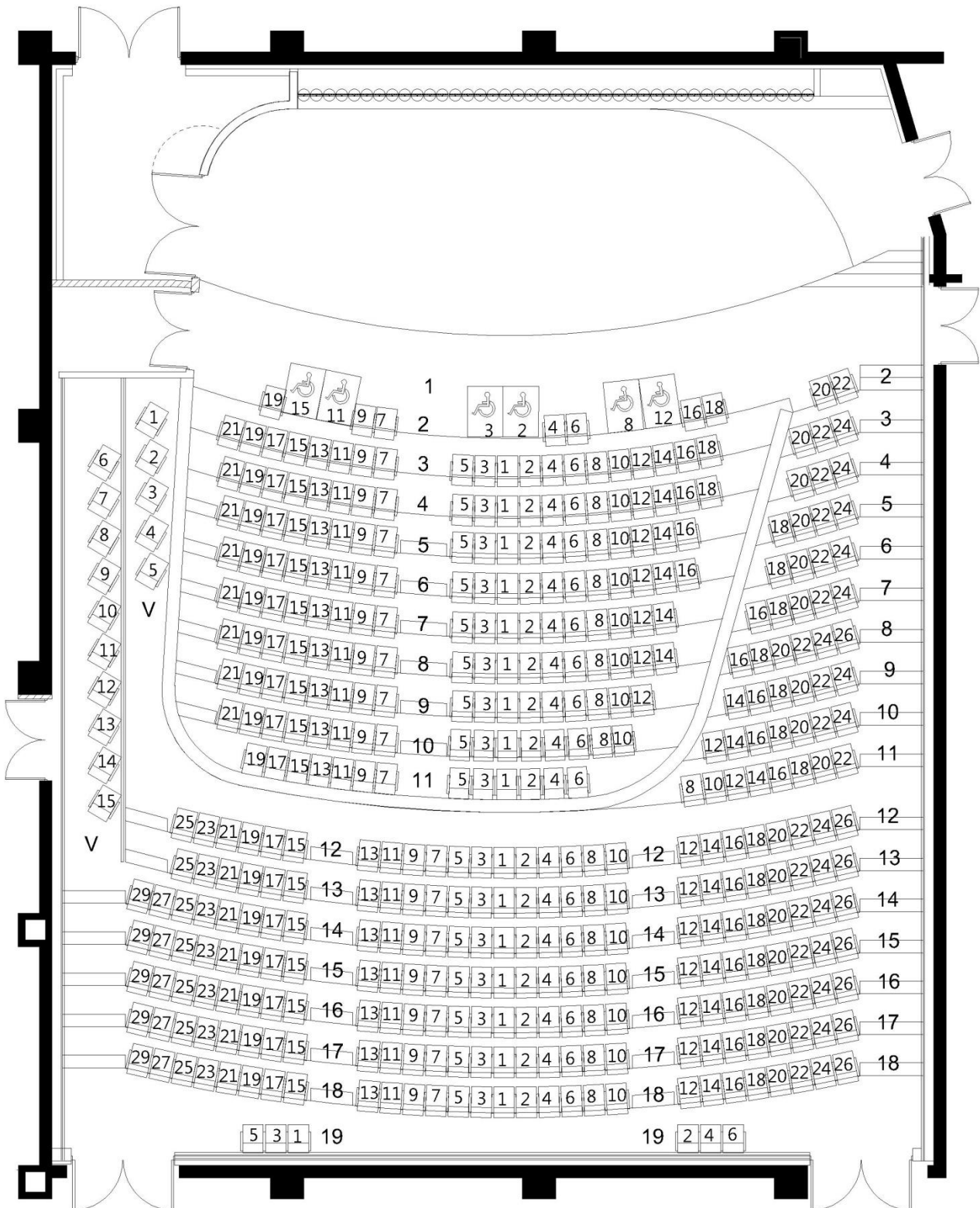

Figure 0.1- Recital Hall Seating plan

0-7 Plan

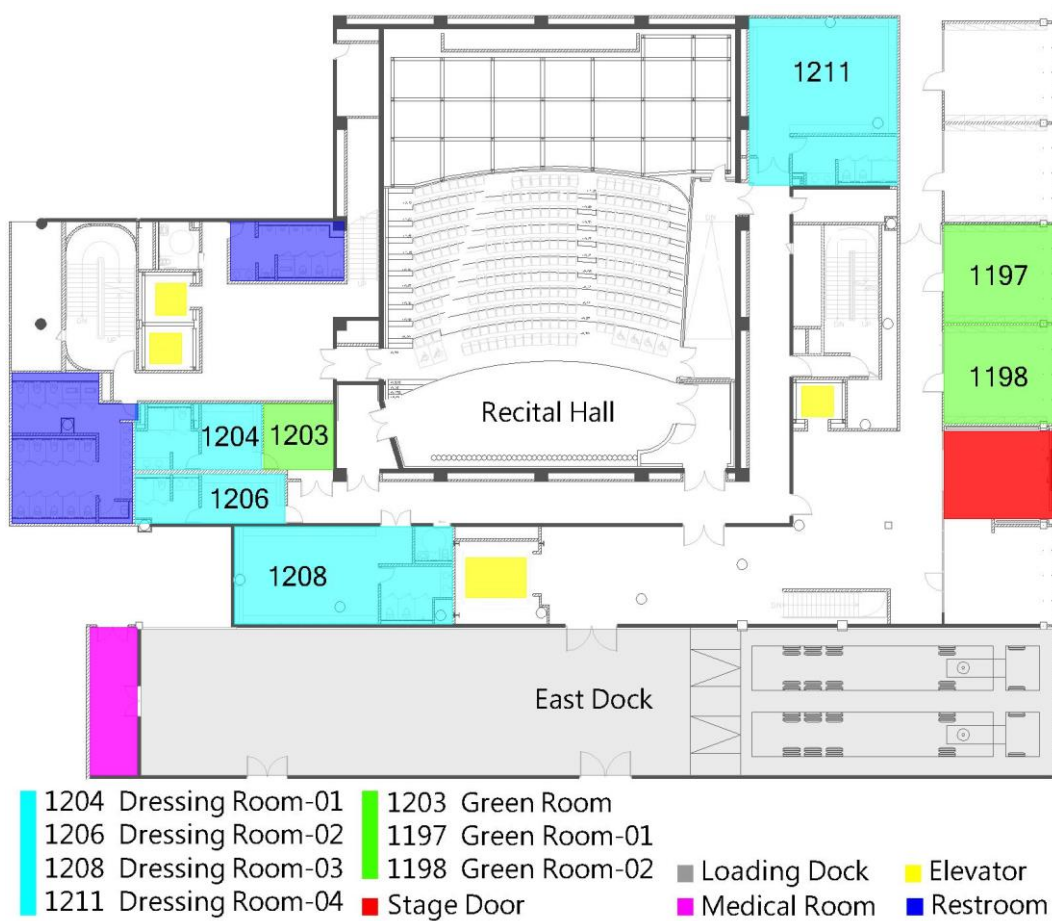

Figure 0.2- Recital Hall Plan

0-8 Section

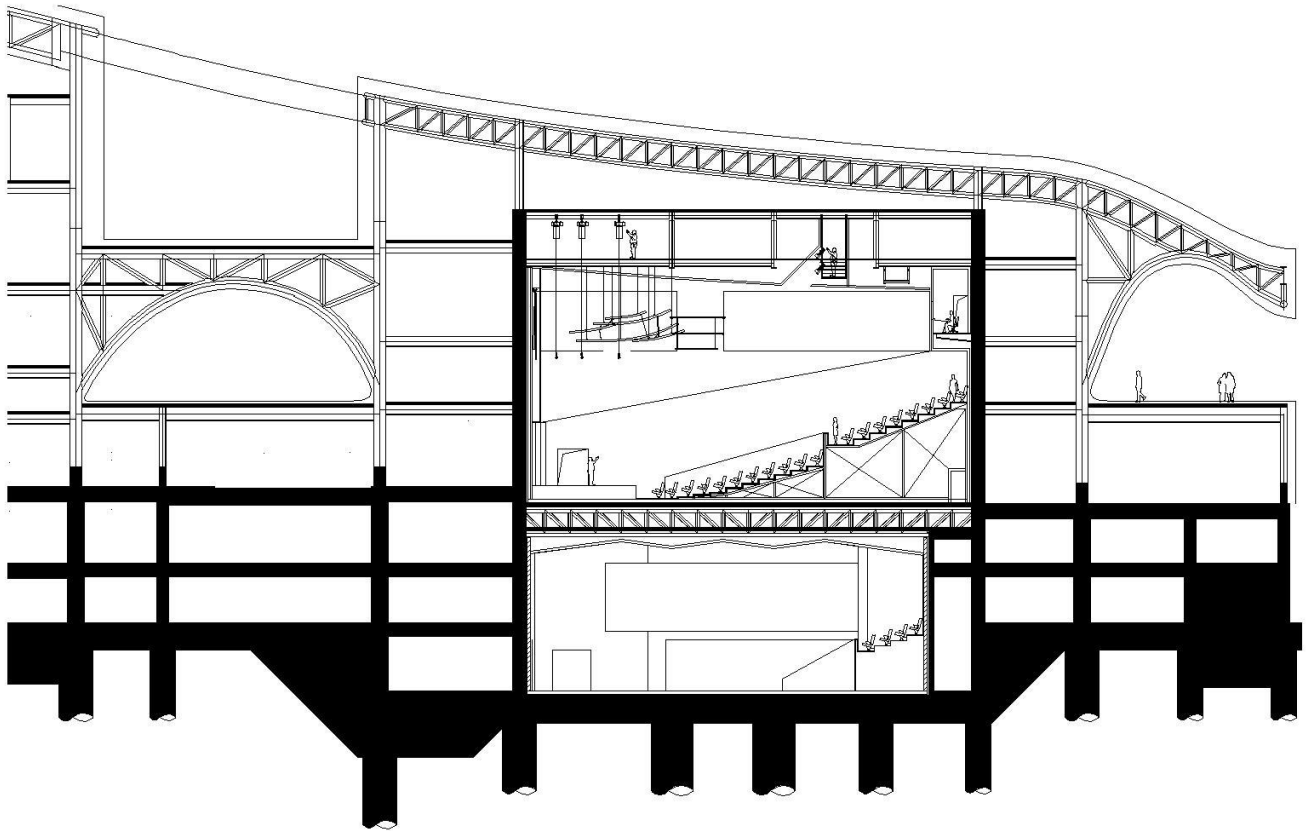

Figure 0.3- Recital Hall Section

1 Stage

1-1 Stage

15.6m (Width) x 5.4m (depth) x 0.7m (height from auditorium floor to stage level)

Sound reflect absorbing drape

Fixed acoustic panel, 8.5m above the stage level

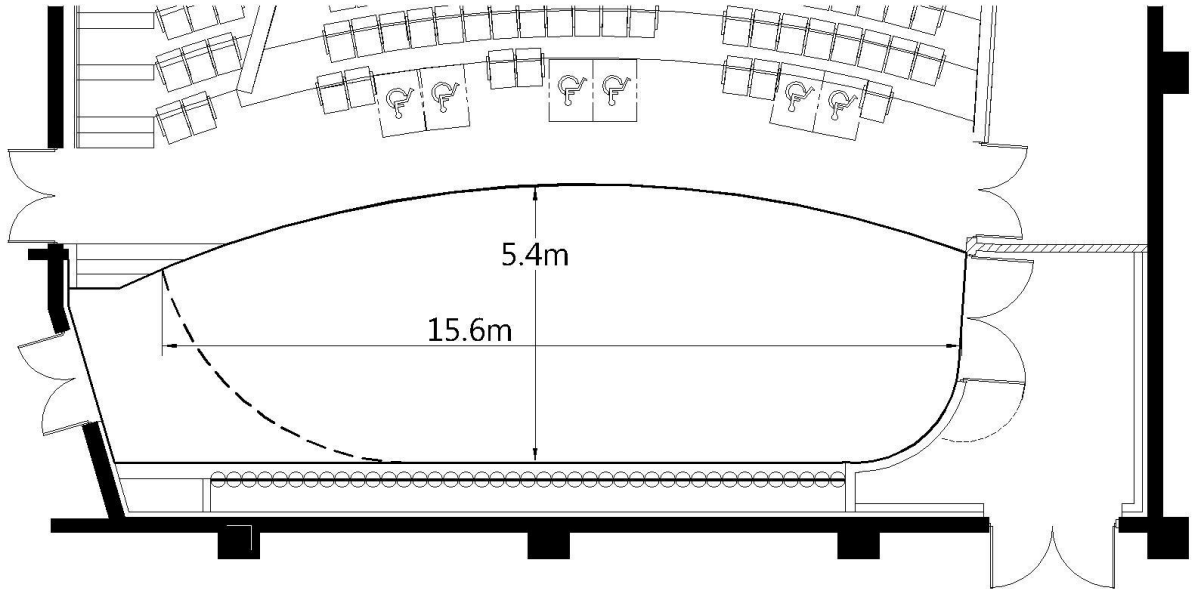

Figure 1.1-Stage Plan

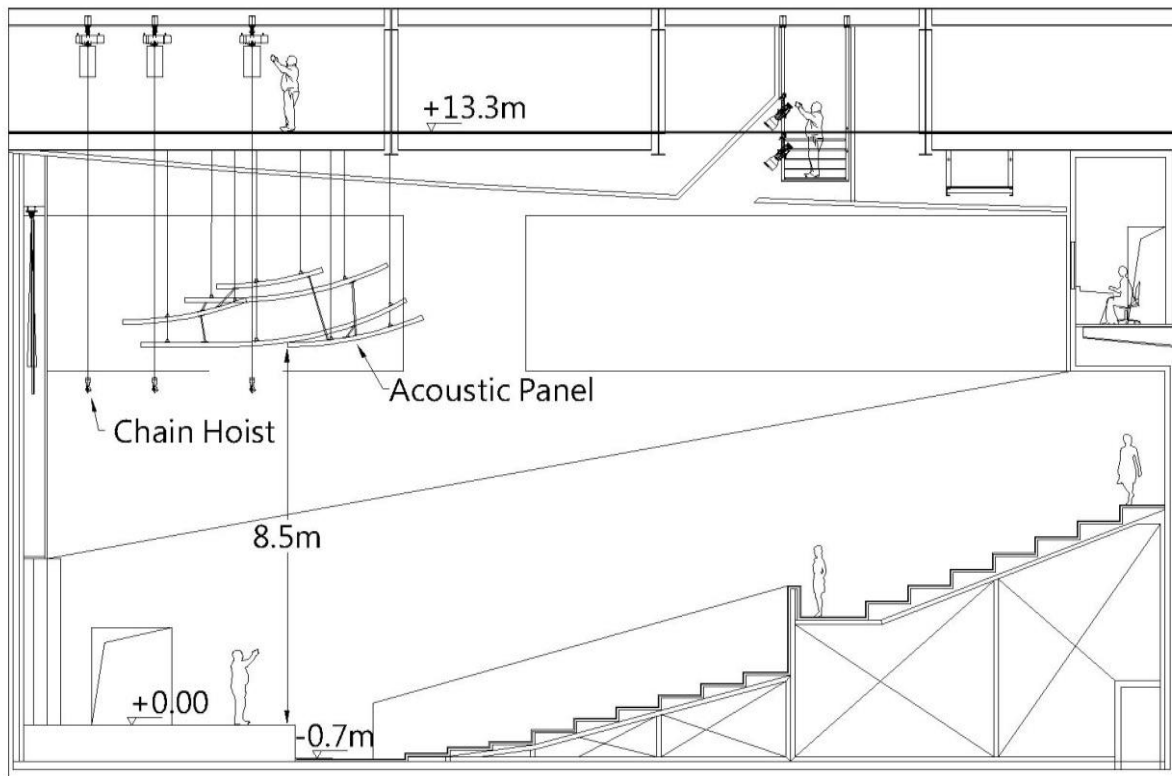

Figure 1.2- Acoustic Panel Plan

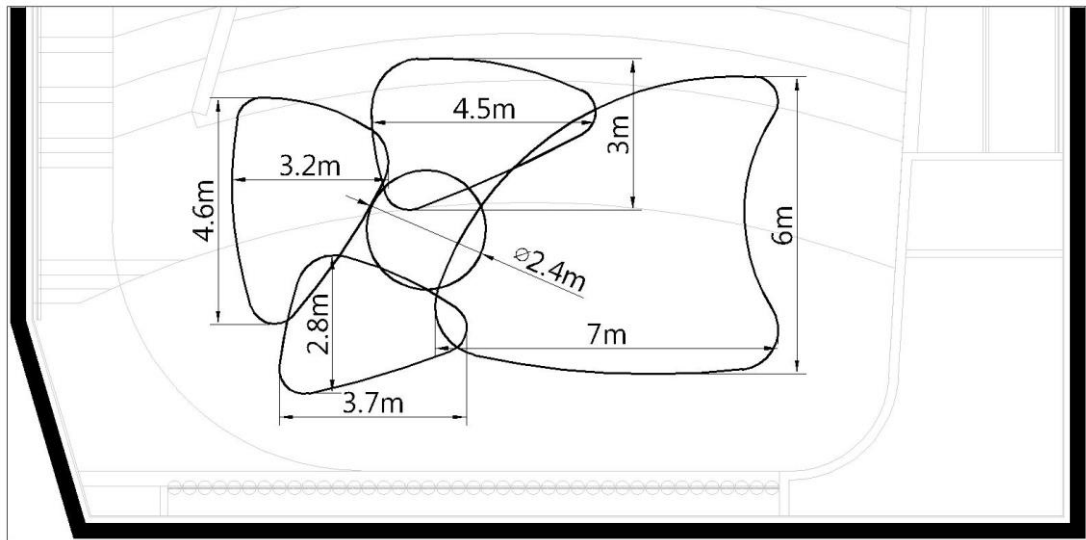

Figure 1.3- Acoustic Panel Plan

1-2 Hoisting

1-2-1 Chain hoist (point load 1000kg, fixed speed: 9.6m/min)

Above Stage, 9 sets, operation length 15m, Movecat PLUSlite chain hoists.

1-2-2 控制系統

The chain hoists control system is located in the grid area and can be connected to both side of stage, through Movecat MRC ID remote controller operates in the stage area.

1-2-3 Trusses

Aluminum triangle trusses	5 sets	0.3m(side)/3m(length)
Eurotruss	9 sets	0.3m(side)/6m(length)

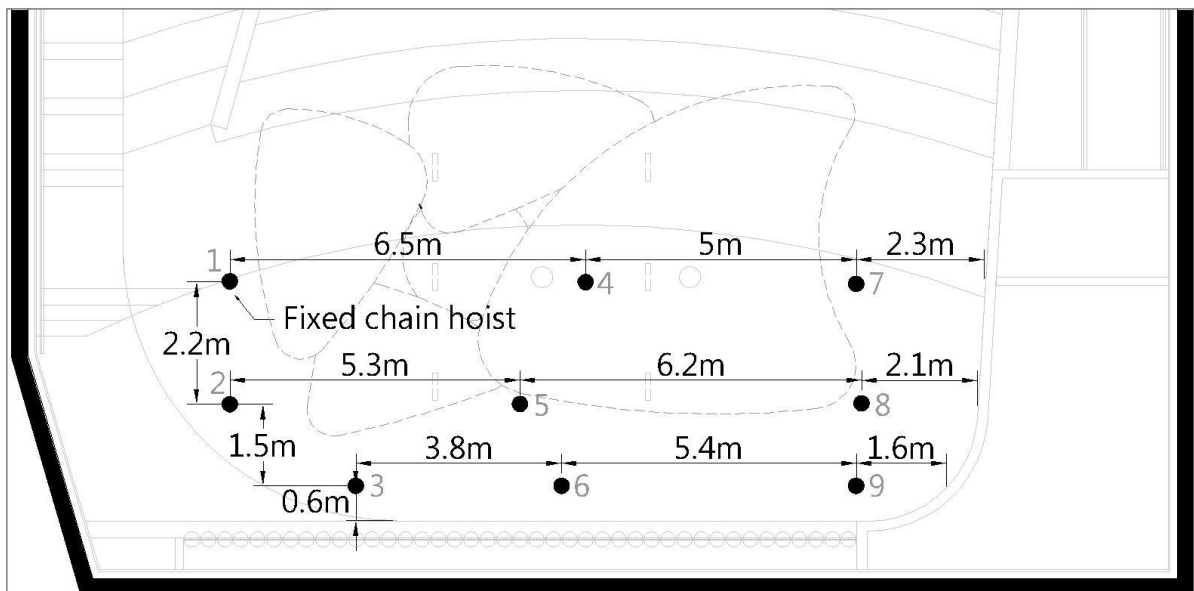

Figure 1.4 - Stage Hoisting plan

2 Lighting

2-1 Lighting instrument

Important : control signal were the network system.

Item	Brand and Model No.	Position	Specifications	Quantity	Frame size	Paid Item
Lighting control console	GrandMA 2 Ultra Light	Control Booth		1		
Dimmer System	State Automation Solution	Dimmer room	220V 3kW/CIR	120ch		
Ellipsoidal Reflector Spotlight	Selecon SPX 14°	Catwalk	750W	15	158x158mm	
		Lighting Box Upper -R/L		4/4		
	Selecon SPX 19°	Lighting Box Lower -R/L	750W	4/4		
	Selecon SPX 15°-35°	Catwalk	750W	8		
	ETC S4 PAR MCM (MFL)	Stage top light	575W	10		
	Selecon SPX 14°		750W	10	158x158mm	
	Selecon SPX 19°		750W	30		
Selecon SPX 15-35°		750W	10			
2KW Fresnel Spotlight 8"	Selecon Arena Theatre 8" Fresnel 7°-60°		2kW	20	245x245mm	
Parabolic Aluminized Reflector Spotlight	Kupo PL-64LB	Lamp : W x 10 · M x 20	1kW	30	254x254mm	
Long Throw Follow Spot	Lycian M2 Model 2040 1.2		1.2kW	1		
Additional Flybar			Bar / Show	1		*
Follow spot operator			Operator / 4 Hour	1		*

*Items with * mark are paid items. Please refer to the rate tables of National Kaohsiung Center for the Arts.*

2-2 Accessories

Item	Specifications	Size	Quantity
Barn door	2kW Fresnel		10
IRIS	For Selecon Ellipsoidal Reflector Spotlight		10
Gobo Holder	For Selecon Ellipsoidal Reflector Spotlight	B size	20
Power Distribution Box	8CIR CEE Form Female Plug		10
Multi-Cable	16pin Multi-Cable	5m	10
		10m	5
		15m	5
Ex-Cable	CEE16A	1.5m	30
		2m	30
		3m	20
		5m	15
		10m	10
		15m	10
Network Cable	RJ45 / Cate 6	5m	10
		10m	10

2-3 Lighting Plan

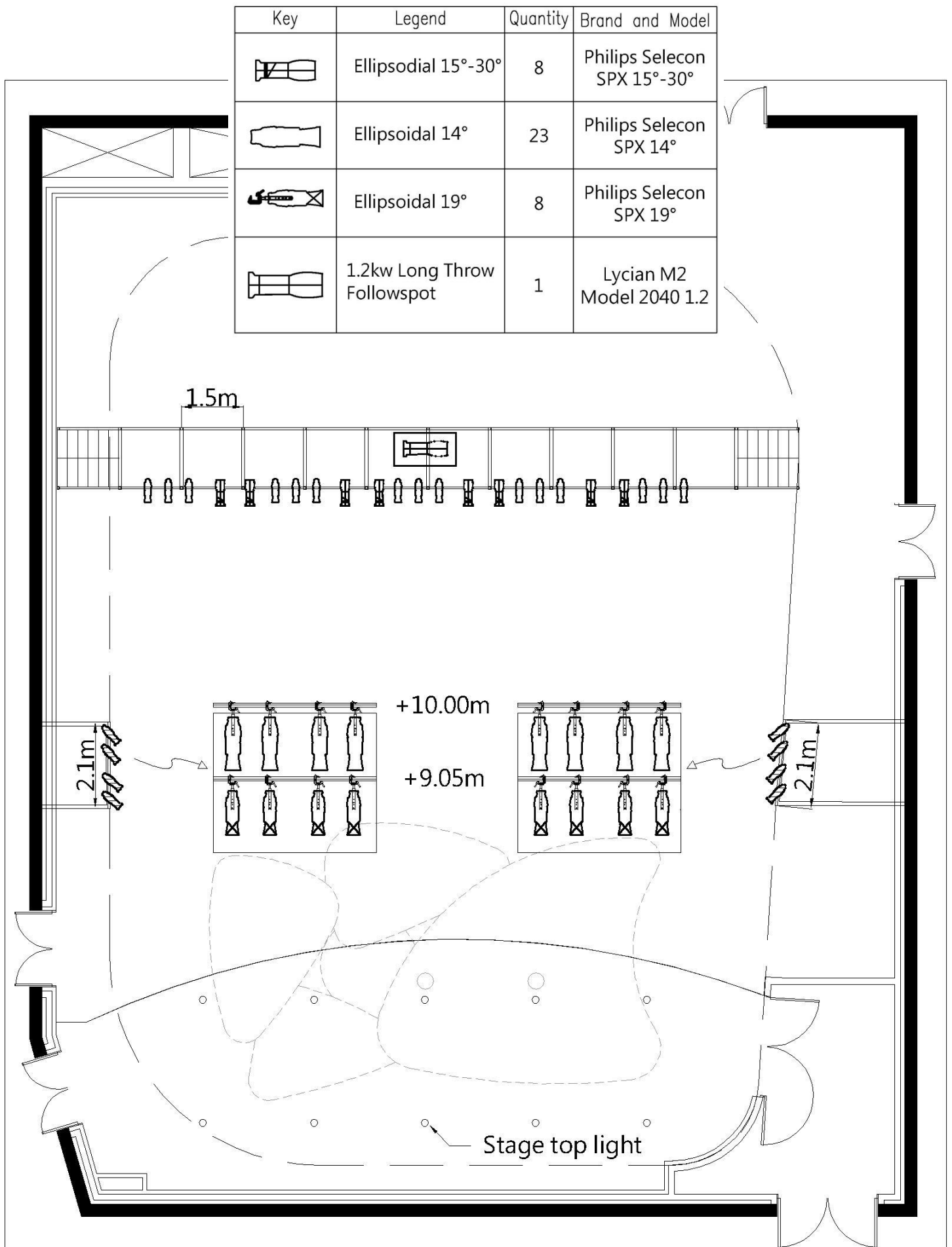

Figure 2.1—Lighting Plan

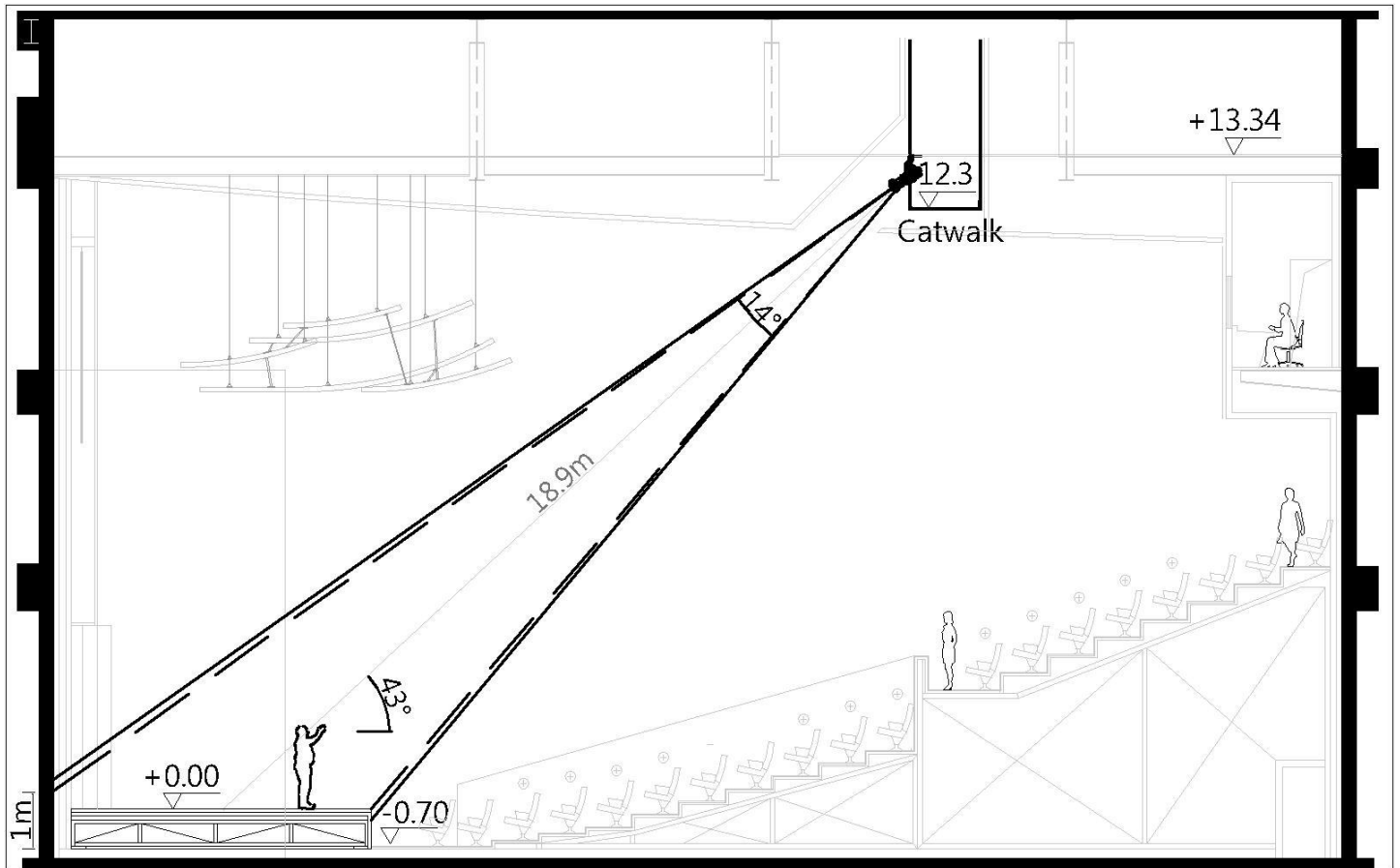

Figure 2.2- Lighting Section

2-4 Lighting Circuit

2-4-1 Stage area

Area and Position	Dimmer Circuit No.	Load	Network Circuit No.
Stage/L	001 ~ 008	3kw	LN01~LN02
Stage/R	009 ~ 016	3kw	LN03~LN04
Up Stage	017 ~ 024	3kw	LN05~LN06
Stage Manager' s Desk/L			LN07~LN10
Control Booth			LN11~LN18

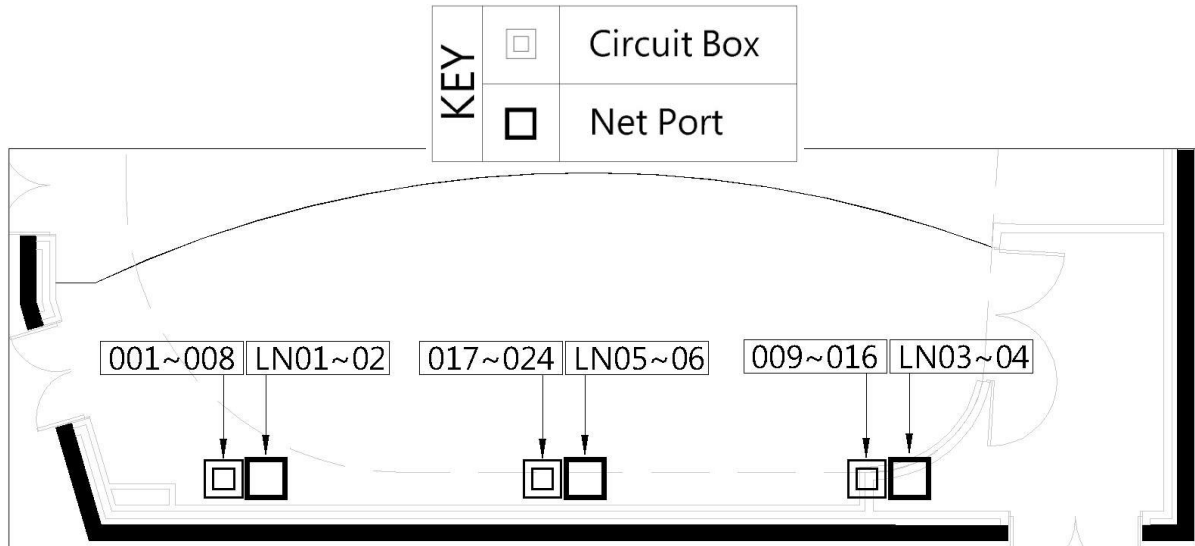

Figure 2.3.1- Stage Area Lighting Circuit Layout

2-4-2 Front of House

Area and Position	Dimmer Circuit No.	Load	Network Circuit No.
Lighting Box/R	025 ~ 028	3kw	LN19~LN20
	029 ~ 032		
Lighting Box/L	033 ~ 036	3kw	LN21~LN22
	037 ~ 040		
Stage Grid area	041 ~ 048	3kw	LN23~LN24
	049 ~ 056	3kw	LN25~LN26
	057 ~ 064		
	065 ~ 072	3kw	LN27~LN28
	073 ~ 080	3kw	LN29~LN30
	081 ~ 088	3kw	LN31~LN32
	089 ~ 096 (For Stage top light)	3kw	LN33~LN34
Catwalk	097 ~ 100	3kw	LN35~LN36
	101 ~ 104	3kw	
	105 ~ 108	3kw	
	109 ~ 112	3kw	
	113 ~ 116	3kw	
	117 ~ 120	3kw	

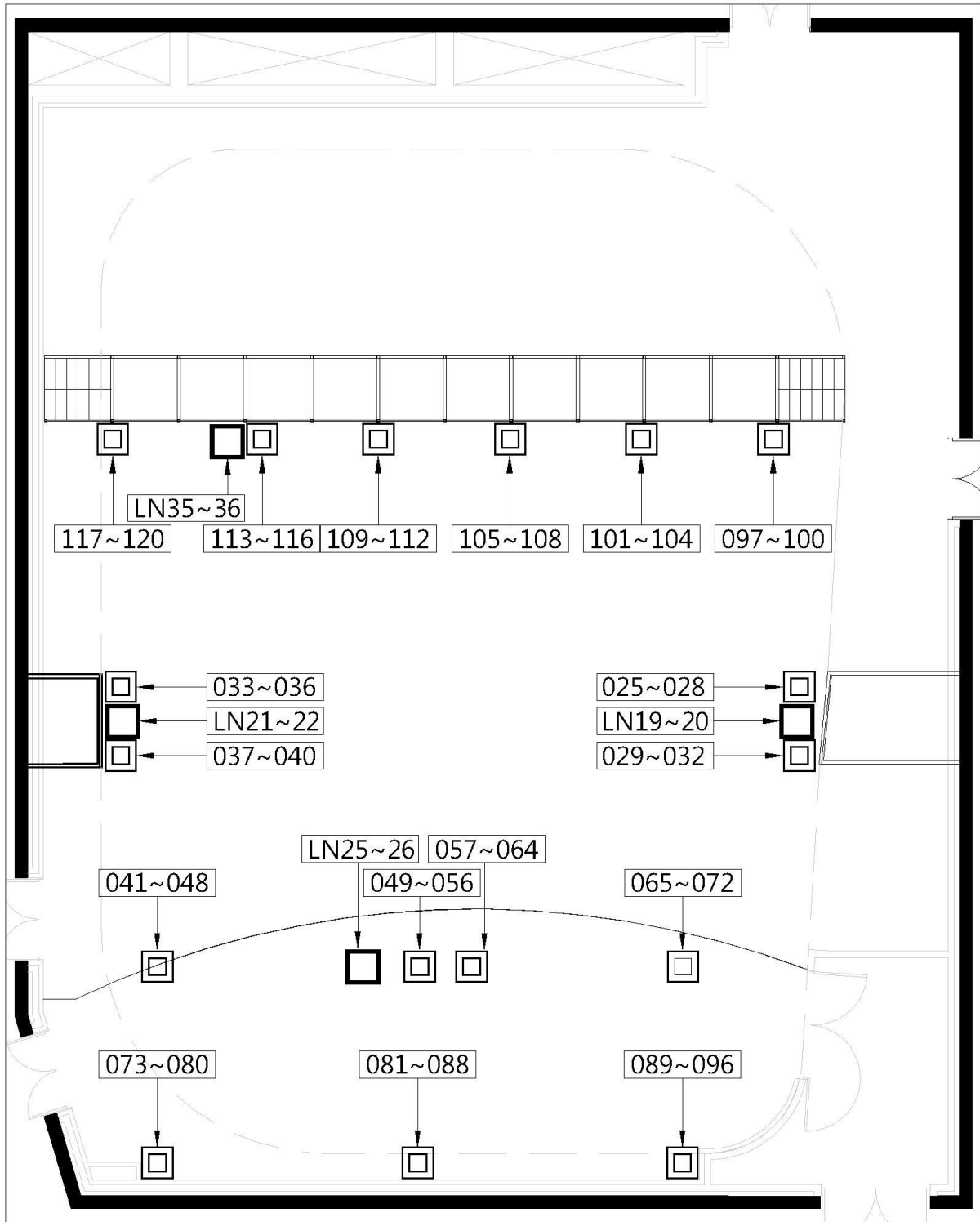

Figure 2.3.2- Grid Area-Lighting Circuit Layout

2-5 Portable Lift

Brand and Model: Snorkel UL-40 (rechargeable)
 Maximum height: 12.1m
 Maximum weight: 136kg
 Quantity: 1

2-6 Additional Power Supply

Function	Position	Specifications	Quantity
Stage	Up Stage Left / Stage Right Waiting Area	3φ4W+G 380V/220V/60Hz (CEE 125A/3P+N+E)	1 / 1
Light		3φ4W+G 220V/120V/60Hz (Camlock 250A)	1 / 1
Sound		3φ4W+G 220V/120V/60Hz (Camlock 50A)	1 / 1



Figure 2.4 - Additional Power Supply

2-7 House Light / Working Light / Blackout

Work lights

Work lights provided white and blue light mode, and the control switch is located on the stage manager' s Desk.
 Lighting area: Side stage entrance, Lighting Box, Grid area and Cat walk.

Auditorium lights

Auditorium lights consists houselights and step lights, which can be separately controlled and dimmed. The control panel is located on the stage manager' s Desk and lighting control room.

Blackout

In accordance with government Fire Services Act, there are many of emergency lights in the venue. We cannot extinguish the emergency lighting for any performance, there will be the minimal lighting levels in the auditorium and backstage areas.

3 Audio/VideoSystems

3-1 Audio Facilities

Item	Quantity	Brand-and Model	Paid Item
Digital speaker	4	Renkus-Heinz IC 8R II	
12" Active stage monitor speakers	4	Renkus-Heinz PN121M/12	
6.5" Active stage monitor speakers	4	Renkus-Heinz PN61	*
2CH Equalizer	2	XTA GQ600	*
AD/DA, I/O Digital I/O Fiber Module	2	Studer D21M	

Items with * mark are paid items. Please refer to the rate tables of National Kaohsiung Center for the Arts.

3-2 Control Room

Item	Quantity	Brand-and Model	Paid Item
Digital mixer	1	Studer Vista 5 M3/32	
Digital I/O Fiber Module	1	Studer D21m	
CD player	1	Tascam CD-500B	*
CD-R recorder / player	1	Tascam CD-RW 901 MK II	*
Multi-circuit recording equipment	1	Joeco BBR1D+2.5" USB 1TB HD	*
Dual track Hard disk recorder	1	Tascam DA 3000	*
Active monitor speakers	2	Dynaudio BM12 Mk III	

Items with * mark are paid items. Please refer to the rate tables of National Kaohsiung Center for the Arts.

3-3 Stage Manager' s Desk

The stage manager' s Desk is equipped with a near-field monitor (Dynaudio BM compact Mk III), screen monitor and intercom equipments.

3-4 Microphone

Item	Quantity	Brand-and Model.	Paid Item
Dynamic microphone	2	Audio Technica AE4100	*
Dynamic microphone	4	Audio Technica ATM250	*
Condenser microphone	2	Audio Technica AE5400	*
Cardioid Condenser microphone	4	Audio Technica AT4021	*
Cardioid Condenser Boundary Microphone	2	Audio Technica U851R	*
Stage reception Microphone	2	DPA 4017B / DPA UA0836 Holder	
Hypercardioid Condenser microphone	4	AKG CK-63-ULS+C480B	*
Cardioid condenser microphone	4	AKG CK-61-ULS+C480B	*
Wireless microphone	2	Sennheiser SKM500G3+MME865	*
Mini wireless microphone	6	Sennheiser SK500G3+MKE2	*
Single channel wireless microphone receiver	8	Sennheiser EW500G3	
wireless microphone wave antenna	2	Sennheiser AD3700	
wave antenna distributor	3	Sennheiser ASA1	
microphone stand	8	K&M 210/6	
microphone stand	8	K&M 210/8	
microphone table stand	4	K&M 259	

Items with * mark are paid items. Please refer to the rate tables of National Kaohsiung Center for the Arts.

3-5 Communications

Item	Quantity	Brand-and Model	Paid Item
Intercom host machine	1	Clear-Com Eclipse HX-Delta	
Phone interface	1	Clear-Com TEL-14	
System interface	1	Clear-Com Helixnet HMS-4	
Double circuit intercom	3	Clear-Com Helixnet HBP-2X	
Fixed intercom microphone/ speak	1	Clear-Com V12PDXY 110/340 Clear-Com V12PDDXY 110 / 340	
Single head receiver microphone	3	Clear-Com CC-300	
Double head receiver microphone	2	Clear-Com CC-400	
Telephone intercom	2	Clear-Com HS-6	
Digital Wireless Intercom set	2	1. Portable wireless sub-station / Clear-Com FS-BP 2. Single-ear headset / Clear-Com CC-300	*

Items with * mark are paid items. Please refer to the rate tables of National Kaohsiung Center for the Arts.

3-6 Locations of Communications

Item Number	Floor	Location
1	1F	stage right entrance
2		stage right entrance
3		FOH Auditorium chair below (Row1-3,11)
4		Loading Dock
5		Recording studio
6		Personal makeup room 1
7		Personal makeup room 2
8	2F	Control room
9		Control room
10	3F	Catwalk

3-7 Stage Cameras and Video Surveillance Systems

Stage monitors are installed in right and left wing stage entrance, first, second, and third floor lobby, master and secondary control room, dressing rooms and green rooms.

Item	Quantity	Brand-and Model	Paid Item
Camera(2/3 inch 3CCD)	1	Panasonic AW-HE870 Panasonic LZ20M85G	
Remote control	1	Panasonic AW-RP50	
Switcher	1	Panasonic AW-RP120	
Mixer circuit	Circuit / Show		*
Video recording	Show	Fixed camera for stage panoramic view recording, only suitable for archived copy.	
Sound recording	Show	Live sound recording, only suitable for archived copy.	

Items with * mark are paid items. Please refer to the rate tables of National Kaohsiung Center for the Arts.

3-8 Paging Systems

Backstage Paging Systems

There are four venues individually Backstage Paging Systems in National Kaohsiung Center for the Arts. For Recital Hall paging available to all dressing rooms, green rooms and passage, it can also available paging to separately 3 zones. The Paging and Program position is located on the stage manager' s console.

Zone 1 : 1203 Green Room 、 1204 Dressing Room-01 、 1206 Dressing Room-02 、 1208 Dressing Room-03 、 1211 Dressing Room-04

Zone 2 : Passage 1202

Zone 3 : 1197 Green Room-01 、 1198 Green Room-02 、 B1120 Usher's room-05 、 B1121 Usher's room-06

4 Backstage Facilities

4-1 Dressing Rooms and Green Rooms

All dressing rooms and green rooms are on the first floor.

No.	Room No.	Name	Capacity	Notes
1	1197	Green room 01	20	Includes table and chairs
2	1198	Green room 02	20	Includes table and chairs
3	1203	Green room	3	Includes dressing mirror, table and chairs.
4	1204	Dressing Room 01	2	Includes mirror, table and chairs, toilet and shower
5	1206	Dressing Room 02	3	Includes mirror, table and chairs, toilet and shower
6	1208	Dressing Room 03	14	Includes upright piano, mirror, table and chairs, toilet and shower
7	1211	Dressing Room 04	13	Includes mirror, table and chairs, toilet and shower

4-2 Orchestra Facilities

No.	Item	Quantity	Notes
1	Chair	40	
2	Ensemble stool	3	
3	Conductor' s chair	1	
4	Music stand	40	
5	Music stand light	40	White light, two brightness mode
6	Conductor' s podium	1	WENGER Base podium:1.09 x 0.97 x 0.15 m Upper podium:0.81 x 0.97 x 0.15 m
7	Conductor' s stand	1	WENGER Desk is 0.69(w)x0.51(d)m Desk height is adjustable from 0.76-1.2m
8	Percussion table stand	2	
9	Endpin stopper	5	

4-3 Pianos (shared between four venues)

No.	Item	Brand	Model Number	Quantity	Notes
1	Model-D Concert grand	Steinway & Sons	D-274	3	*
2	Concert grand	FAZIOLI	F308	1	*
3	Grand Piano	YAMAHA	C7XPE	1	*
4	Grand Piano	KAWAI	SK-6L	1	*
5	Celesta	Schiendmayer	5 ½ Octave Studio model	1	*
6	Harpsichord	J.C.NEUPERT	Hensch	1	*

*Items with * mark are paid items. Please refer to the rate tables of National Kaohsiung Center for the Arts.*

Pianos shared with four venues ,booking in advance is required.

The piano should be tuned by WEIWUYING' s contracted piano technician. Piano hire fees do not includes tuning cost.

4-4 Loading Dock

4-4-1 East Dock

Recital Hall and Concert Hall use the East Dock for loading and unloading. The dock is equipped with two hydraulic dock leveler that can be adjusted according to the required height.

Dock Dimension

Width: 8.7m

Clearance: 4.38m

Height from dock to ceiling: 3.8m

Height from dock to floor: 0.98m

Stage entrance: 1.95m (width) x 2.2m (height)

4-4-2 Handling equipment

Platform Trolley (with handle)x10 (0.9m x1.8m)

1.5mt Stand-Up Automatic Electric Forklift x1

3mt Manual Hydraulic Pallet Jack x1

West Dock Handling equipment

The West Dock equipment is mainly used by Opera House and Playhouse. In need, please requests in advance.

Platform Trolley x20 (1.2m x2.4m)

2.5mt Electric Forklift x1

1.5mt Stand-Up Automatic Electric Forklift x1

3mt Manual Hydraulic Pallet Jack x2

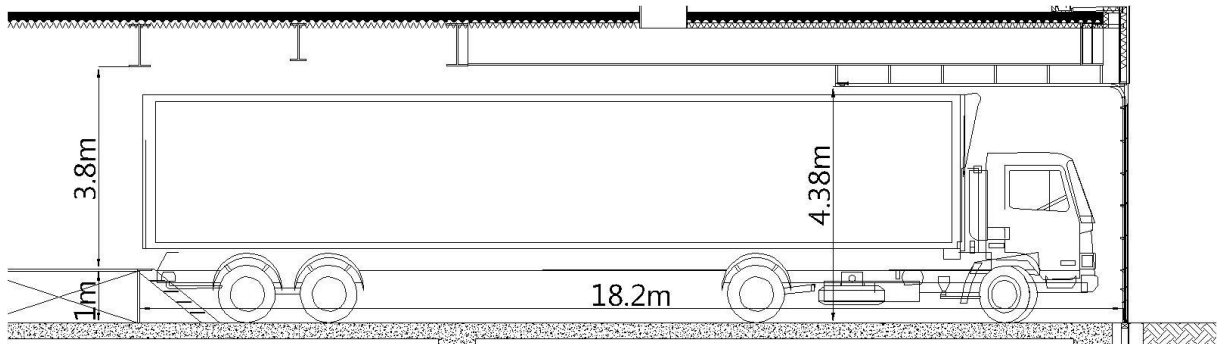

Figure 4.1- East Loading Dock Plan

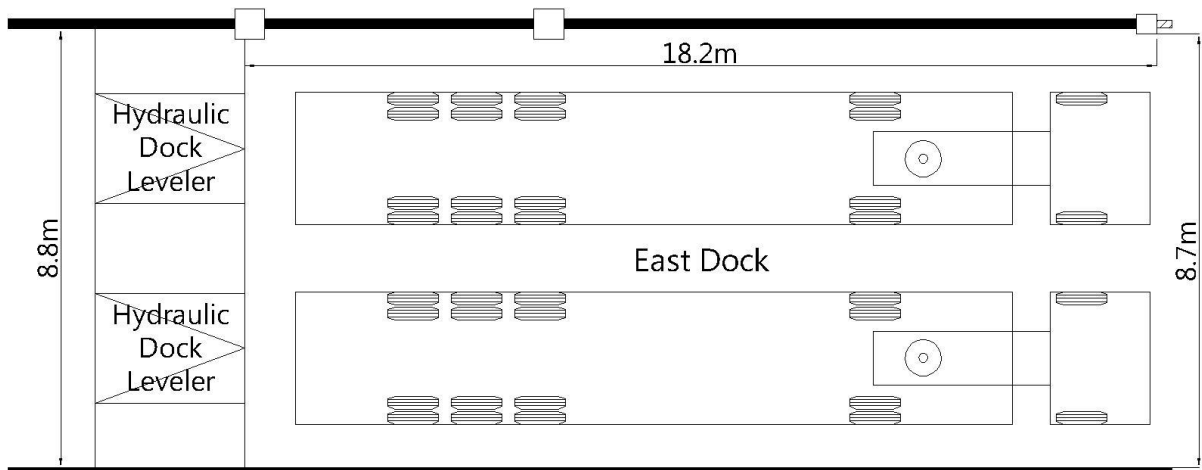

Figure 4.2- East Loading Dock Section

4-4-3 Loading Flow

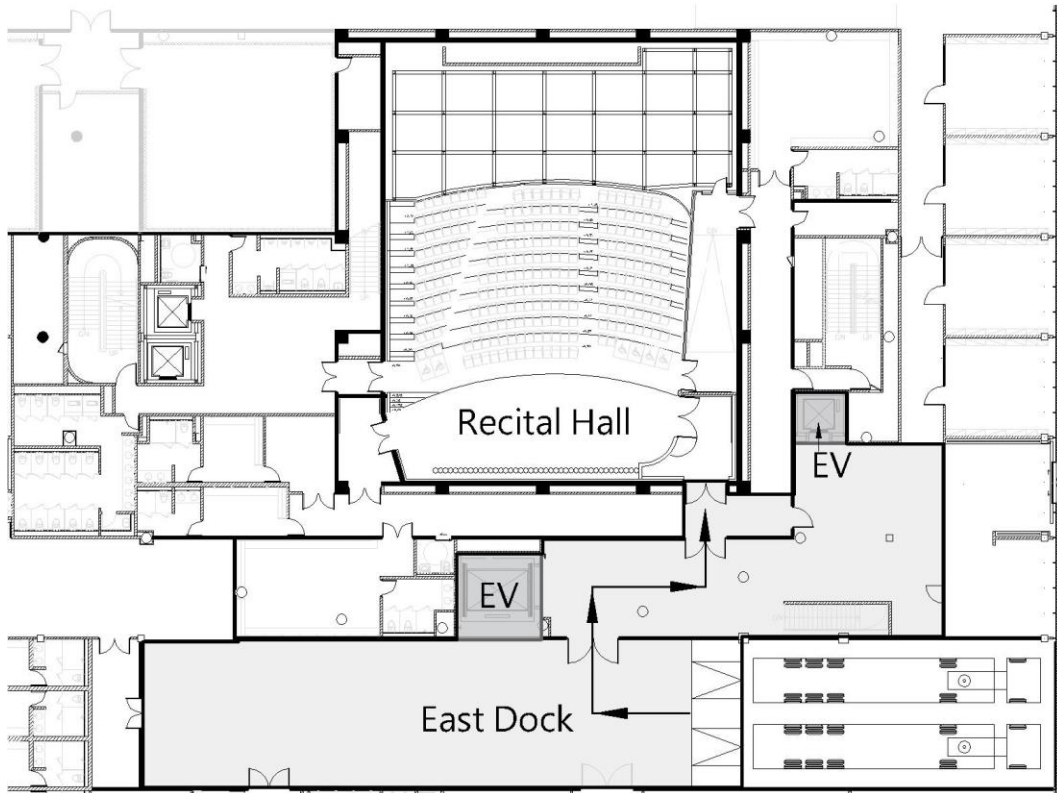

Figure 4.3 - Loading Flow

4-4-4 Hydraulic Dock Leveler

Capacity: 22.6mt

Area: 198cm (width) x 221.9cm (length)

Elevation: +/- 30.5cm

Quantity: 2 on east dock

4-5 Other Facilities

4-5-1 Rehearsal Rooms

There is no rehearsal studio dedicated to the Playhouse. Additional rehearsal space is limited across the WeiWuYing. There are 13 different function and accommodated rehearsal studios, these available for hire between four major theatres .Requests should be discussed well in advance to determine availability. The hire fees please refer to the rate tables of National Kaohsiung Center for the Arts.

Room No.	Name	Dimension (Length x Width x Height / m)	Notes
B313	Orchestra Studio	23.2×18.1×7.8	1. fixed auditorium < 84seats > 2. Grand Piano ,Chair , Ensemble stool 3. Wooden floor 4. Sound absorption curtain
B304	Chorus Rehearsal Room	17×11.2×8.8	1. Grand Piano ,Chair , Ensemble stool 2. Wooden floor 3. Sound absorption curtain
1171	Rehearsal Studio-01	13.1×21.5×11.7	1. Grand Piano 2. Wooden floor covered black color dance floor 3. Wall mount glassless mirrors x 1 side Opera House rehearsal room
1182	Rehearsal Studio-02	12.8×22.3×4	1. Wooden floor covered gray color dance floor 2. Sound absorption wall x 2 side 3. Wall mount glassless mirrors x 2 side
1184	Rehearsal Studio-03	12.8×22.3×4	1. Grand Piano 2. Wooden floor covered gray color dance floor 3. Sound absorption wall x 2 side 4. Wall mount glassless mirrors x 2 side
1186	Rehearsal Studio-04	12.8×22.3×4	1. Grand Piano 2. Wooden floor ,black color dance floor 3. Wall mount glassless mirrors x 2 side 4. Fixed Ballet barre on the single sided wall mirror x 2
		6.6×8.8 ×3	Rehearsal Studio-04 use only Green Room-01(With dressing room)
1192	Rehearsal Studio-05	12.8×22×4	1. Grand Piano 2. Wooden floor , black color dance floor 3. Wall mount glassless mirrors x 2 side 4. Fixed Ballet barre on the single sided wall mirror x 2
		6.6×8.8 ×3	Rehearsal Studio-05 use only Green Room-02(With dressing room)
B1111	Rehearsal Studio-06	8.5×9×2.7	1. Upright piano ,Chair , Music stand 2. Wooden floor 3. Sound absorption wall
B1112	Rehearsal Studio-07	6.3×5.2×2.7	1 Chair , Music stand 2. Wooden floor 3. Sound absorption wall
B1113	Rehearsal Studio-08	5.7×8.4×3.3	1. Chair , Music stand 2. Wooden floor 3. Sound absorption wall
B1114	Rehearsal Studio-09	5.7×5.6×3.3	1. Chair , Music stand 2. Wooden floor 3. Sound absorption wall
B1115	Rehearsal Studio-10	5.7×5.6×3.3	1. Chair , Music stand 2. Wooden floor 3. Sound absorption wall
B1116	Rehearsal Studio-11	5.7×5.6×3.3	1. Chair , Music stand 2. Wooden floor 3. Sound absorption wall

4-5-2 Carpentry Shop / Metal Shop / Costume Shop / Laundry Room

National Kaohsiung Center for the Arts is equipped with basic production facilities, include Carpentry Shop, Metal Shop, Costume Shop, and laundry rooms. Those for hire between four major theatres .The hire fees please refer to the rate tables of National Kaohsiung Center for the Arts.

Room No.	Name	Dimension (Length x Width x Height / m)	Notes
1002	Carpentry Shop	11.9×19.7×3	Basic wood crafts and electrical tools
1002A	Metal Shop	8.9×5.8×3	General welding facilities for repairs
1165	Costume Shop-01	5.9×10.2×3	Basic facilities for the maintenance of costume; Sewing machine, overlock machine and steam / iron equipment
1181	Costume Shop-02	5.8×11.8×3	
1163	Laundry Room-01	5.8×4.9×3	Washing machine, tumble dryers, sink and clothes folding table
B1019	Laundry Room-02	6×8.2×3	